



# User Manual

SR-LV14G Li-ion Battery System

V1.0 2026-05-18

# CONTENT

<b>1. About This Manual.....</b>	<b>03</b>
1.1 Applicable Model.....	03
1.2 Target Audience .....	03
1.3 Symbol Definition.....	03
<b>2. Safety Precaution .....</b>	<b>04</b>
2.1 General Safety .....	04
2.2 Battery Safety .....	05
2.3 Emergency Measures .....	07
2.4 EU Declaration of Conformity.....	07
<b>3. Product Introduction .....</b>	<b>08</b>
3.1 Product Overview.....	08
3.2 Application Scenarios .....	10
3.3 Appearance.....	11
<b>4. Check and Storage .....</b>	<b>13</b>
4.1 Check Before Receiving.....	13
4.2 Deliverables .....	13
4.3 Storage .....	14
<b>5. System Installation.....</b>	<b>15</b>
5.1 Installation Requirements.....	15
5.2 Installing the Battery System .....	16
5.2.1 Moving the Equipment .....	16
5.2.2 Installing the Battery System.....	17
<b>6. Electrical Connection.....</b>	<b>20</b>
6.1 Safety Precaution .....	20
6.2 Electrical Connection .....	20
6.3 Connecting the PE cable.....	21
6.4 Connecting the Power Cable .....	22
6.5 Connecting the Communication Cable .....	22
6.6 Installing the Protective Cover .....	23
<b>7. System Operation.....</b>	<b>24</b>
7.1 Check Before Power ON.....	24
7.2 Power On.....	24
7.3 Indicator Status .....	25
<b>8. Maintenance .....</b>	<b>26</b>
8.1 Power OFF the Battery System.....	26
8.2 Routine Maintenance .....	26
8.3 Common Problem Handling.....	27

# 1. About This Manual

This manual describes the product information, installation, electrical connection, commissioning, troubleshooting, and maintenance. Read through this manual before installing and operating the product. All the installers and users have to be familiar with the product features, functions, and safety precautions. This manual is subject to update without notice. For more product details and latest documents, visit <https://www.sumrayinverter.com>

## 1.1 Applicable Model

This manual applies to the listed model below:



- SR-LV14G-L1
- SR-LV14G-L2
- SR-LV14G-L3
- SR-LV14G-L4

## 1.2 Target Audience

This manual applies to trained and knowledgeable technical professionals only. The technical personnel has to be familiar with the product, local standards, and electric systems.

## 1.3 Symbol Definition

Different levels of warning messages in this manual are defined as follows:

 <b>DANGER</b>
Indicates a high-level hazard that, if not avoided, will result in death or serious injury.
 <b>WARNING</b>
Indicates a medium-level hazard that, if not avoided, could result in death or serious injury
 <b>CAUTION</b>
Indicates a low-level hazard that, if not avoided, could result in minor or moderate injury
<b>NOTICE</b>
Highlights key information and supplements the texts. Or some skills and methods to solve product-related problems to save time.

## 2. Safety Precaution

Please strictly follow these safety instructions in the user manual during the operation.

### NOTICE

The System is designed and tested to strictly comply with related safety rules. Read and follow all the safety instructions and cautions before any operations. Improper operation might cause personal injury or property damage as the System are electrical equipment.

### 2.1 General Safety

#### NOTICE

- The information in this user manual is subject to change due to product updates or other reasons. This guide cannot replace the product labels or the safety precautions in the user manual unless otherwise specified. All descriptions in the manual are for guidance only.
- Before installations, read through the user manual to learn about the product and the precautions.
- All operations should be performed by trained and knowledgeable technicians who are familiar with local standards and safety regulations.
- Use insulating tools and wear personal protective equipment when operating the equipment to ensure personal safety. Wear anti-static gloves, cloths, and wrist strips when touching electronic devices to protect the inverter from damage.
- Strictly follow the installation, operation, and configuration instructions in this guide and user manual. The manufacturer shall not be liable for equipment damage personal injury if you do not follow the instructions. For more warranty details, please visit <https://www.sumrayinverter.com>

## 2.2 Battery Safety















### DANGER

- High voltage exists during the battery system running. Ensure that the equipment has been powered off to avoid the risk of electric shock before operating the device in the system. Strictly follow all safety precautions outlined in this manual and safety labels on the equipment during the operation.
- The battery used with the inverter shall be approved by the inverter manufacturer. The approved battery list can be obtained through the official website.
- Do not disassemble, modify, or replace any part of the battery without official authorization from the manufacturer. Otherwise, it may cause electrical shock or damages to the equipment for which the manufacturer shall not be held responsible.
- Do not hit, pull, drag, squeeze or step on the System or put the battery into fire. Otherwise, the battery may explode.
- Do not place the battery in a high temperature environment. Make sure that there is no direct sunlight and no heat source near the battery. When the ambient temperature exceeds 60 °C, it may cause fire.
- Do not use the battery module or power control unit if it is defective, broken, or damaged. Damaged battery modules may leak electrolyte.
- To protect the battery pack and its components from damage during transportation, please ensure that the transportation personnel are professionally trained. All operations during the transportation have to be recorded. The equipment shall be kept in balance to avoid falling down.
- Consider the weight of the equipment before moving it. Assign enough personnel to move the equipment to avoid personal injury.
- Contact after-sale service immediately if the battery is not able to be started. Otherwise, the battery might be damaged permanently.
- Do not move the battery when it is working. Contact after-sales service if the battery shall be replaced or added.

### CAUTION

- Protect the battery system from damage during transportation and storage.
- The transportation must be carried out by trained professionals. All operations during the process have to be recorded.
- Keep the equipment stable to avoid dumping, which can result in equipment damage and personal injuries.
- Place the cables at least 30mm away from the heating components or heat sources, otherwise the insulation layer of the cables may be aging or broken due to high temperature.
- Tie the same type cables together, and place cables of different types at least 30mm apart. Do not place the cables entangled or crossed.

**Label Description**

	Potential risks exist. Wear proper Personnel Protective Equipment before any operations.		Install the equipment away from open flames or fire sources.
	High voltage exists during the equipment's running. Ensure the equipment is power off before any operations.		Keep the equipment away from children.
	Operate the equipment properly to avoid explosion.		Do not lift the equipment after the wiring is completed or when the equipment is working.
	The equipment contains corrosive electrolytes. In case of a leak in the equipment, avoid contact the leaked liquid or gas		Do not disconnect or plug and unplug the DC connectors during the operation of the equipment.
	The battery contains flammable materials, beware of fire.		Recycle regeneration mark
	Read through the user manual before any operations.		CE Mark
	Pay attention to wear personal protective equipment during installation, operation and maintaining of the equipment.		Grounding point.
	Do not dispose of the equipment with household garbage at its end of life. Dispose it according to local laws and regulations or send it to the manufacturer		

## 2.3 Emergency Measures

### ■ Battery Electrolyte Leakage

If the battery module leaks electrolyte, avoid contact with the leaking liquid or gas. The electrolyte is corrosive. It will cause skin irritation or chemical burn to the operator. Anyone contact the leaked substance accidentally has to do as following:

- **Breath in the leaked substance:** Evacuate from the polluted area, and seek immediate medical assistance.
- **Skin contact:** Thoroughly wash the touch area with soap and clean water, and seek immediate medical assistance.
- **Ingestion:** Induce vomiting, and seek immediate medical assistance.
- **Eye contact:** Rinse your eyes for at least 15 minutes with clean water and seek immediate medical assistance.

### ■ Fire

- The battery may explode when the ambient temperature exceeds 150°C. Poisonous and hazard gas may be released if the battery is on fire.
- In the event of a fire, please make sure that the carbon dioxide extinguisher or Novec1230 or FM-200 is nearby.
- The fire cannot be put out by water or ABC dry powder extinguisher. Firefighters are required to wear full protective clothing and self-contained breathing apparatus.

## 2.4 EU Declaration of Conformity

Suzhou Sumray Digital Energy Technology Co.Ltd hereby declares that the product without wireless communication modules sold in the European market meets the requirements of the following directives:

- Electromagnetic compatibility Directive 2014/30/EU (EMC)
- Electrical Apparatus Low Voltage Directive 2014/35/EU (LVD)
- Battery Directive 2006/66/EC and Amending Directive 2013/56/EU
- Waste Electrical and Electronic Equipment 2012/19/EU
- Registration, Evaluation, Authorization and Restriction of Chemicals (EC) No 1907/2006 (REACH)

### 3. Product Introduction

#### 3.1 Product Overview

##### Intended usage

The battery system can store and release electricity according to the requirements of the photovoltaic energy storage system, and both the input and output ports of this energy storage system are low-voltage DC electricity

##### Performance Parameter

Technical Parameters	SR-LV14G-L1	SR-LV14G-L2	SR-LV14G-L3	SR-LV14G-L4
<b>Battery Characteristics</b>				
Cell Type	LFP (LiFePO4)			
Battery Module	LV14G-M*1	LV14G-M*1 LV14G-S*1	LV14G-M*1 LV14G-S*2	LV14G-M*1 LV14G-S*3
Capacity	290Ah	580Ah	870Ah	1160Ah
Rated Voltage	48V			
Rated Energy	13.92kWh	27.84kWh	41.76kWh	55.68kWh
Usable Energy	13.92kWh	27.84kWh	41.76kWh	55.68kWh
Operation Voltage	42V~54V			
Max Charge/Discharge Current	100A/100A	200A/200A	300A/300A	300A/300A
Standard Charge Voltage	48V			
Standard Charge/Discharge Current	100A/100A	200A/200A	300A/300A	300A/300A
Rate DC Power	4.8kW	9.6kW	14.4kW	14.4kW
Max Charge/Discharge power	5.4kW	10.8kW	16.2kW	16.2kW
Depth Of Discharge	100%			
Communication method	CAN			
<b>Operation Condition</b>				
Operation Temperature	Charging: 0 ~ 50°C, Discharging: -20~50°C			
Cooling Mode	Natural Convention			
Altitude	≤3000m			
Relative Humidity	0~95%			
<b>General</b>				
Weight	120±5kg	230±10kg	340±15kg	450±20kg
Dimensions	850*440*360mm	850*440*590 mm	850*440*820 mm	850*440*1050 mm
Installation Method	Stack			
Corrosion protection	C4			
Protection level	IP66			
Transportation	UN38.3/SDS			
Country of Manufacture	China			

## Usable energy

### NOTICE

- The battery system supports capacity expansion. A maximum of four battery modules can be used to extend the usable energy of the battery system. Expand the battery system capacity in strict compliance with the expansion requirements. Contact the dealer or manufacturer for more details. Failure to follow the requirements may result in an undervoltage, over-voltage or voltage difference fault in the battery system.
- Actual height varies slightly. Refer to the actual installation height

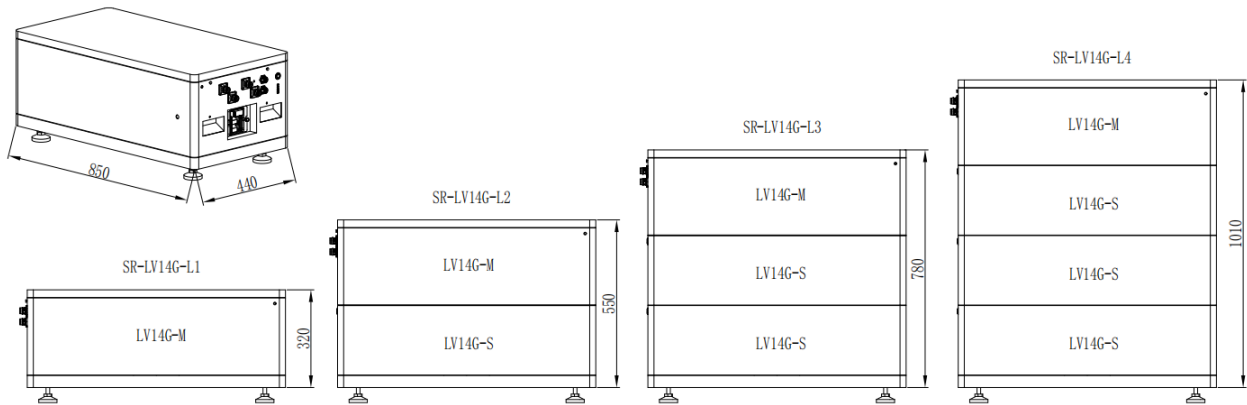

### 3.2 Application Scenarios

#### NOTICE

Install the circuit breaker between the inverter and the battery in compliance with local laws and regulations.

Recommended specifications:

- Nominal voltage  $\geq 150V$
- When a single battery system is applied, the normal current  $\geq 400A$

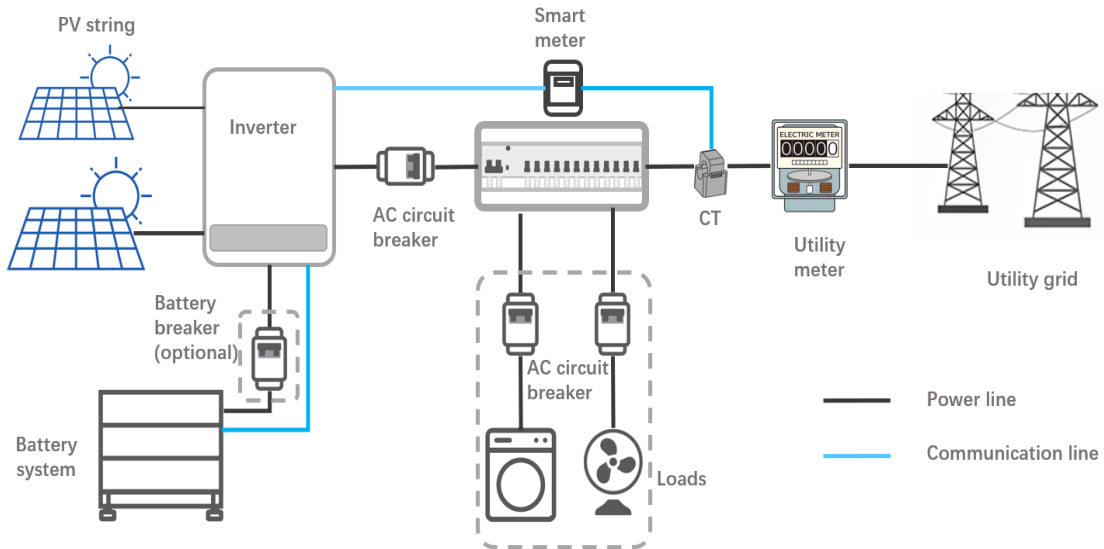

#### Approved inverter list

Scan the QR code below or visit the official website to get the Battery Compatibility Overview.



Sumray

### 3.3 Appearance

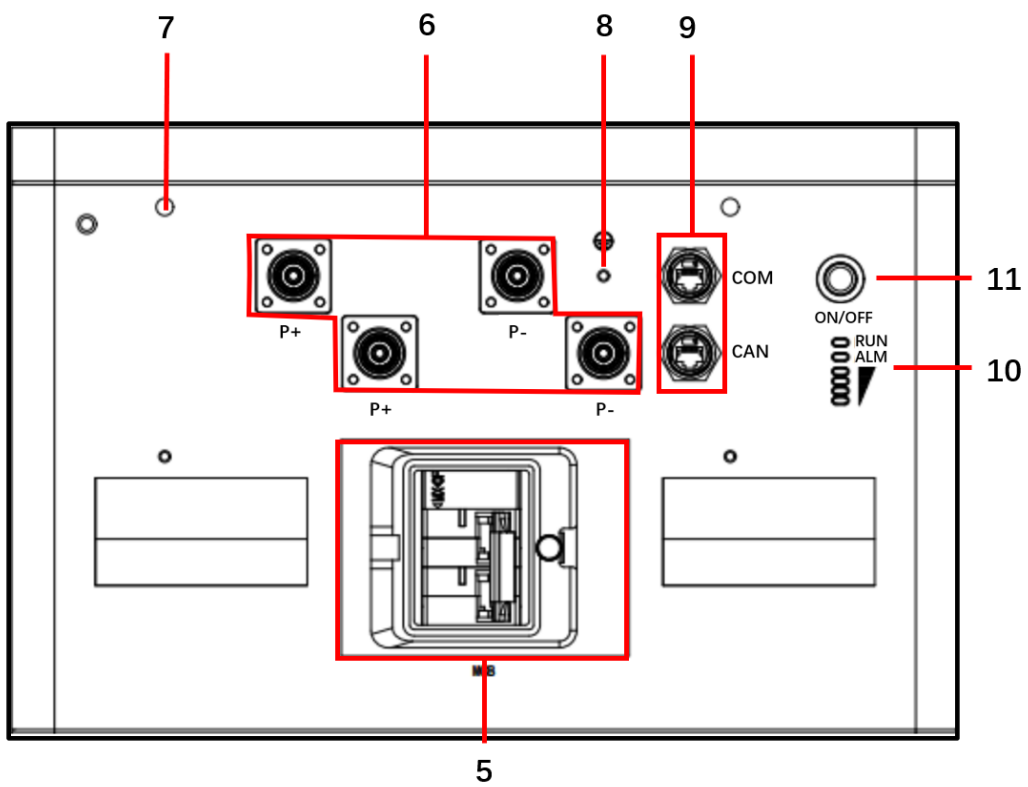
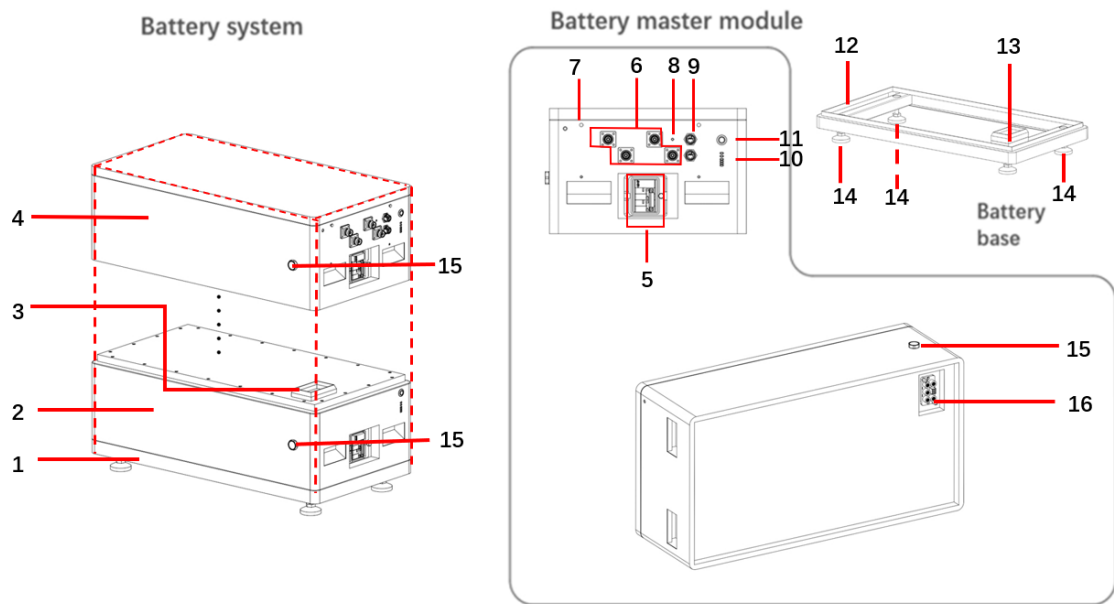

No	Parts	Description
1	Battery base	Height-adjustable base
2	Slave Battery module	2 slave modules can be connected in the battery system.
3	Battery parallel connection interface	Connects the battery module to the upper module or to the master battery module.
4	Master battery module	Controls battery system
5	Battery module breaker	Switches the battery system on or off
6	DC cable port (BAT)	Connects the DC cables of the battery system to the inverter. Includes two P+ ports and two P- ports. The two P+ or P- port are functionally identical.
7	Protective cover installation hole	Used for installing protective cover. Some version of battery has these installation holes
8	Grounding point	Connects grounding cables to the grounding points for protection.
9	Communication terminal (CAN/COM)	CAN: The port is connected to the inverter CAN interface through the communication cable COM: This port is used for debugging
10	Multi-functional indicator light	multi-function button indicator to check the battery system working status
11	Power button	Press down button, to start the battery system, Use the battery power to provide starting voltage for the inverter
12	Battery installation limit	Fix the battery to prevent it from tilting
13	Battery module parallel connection interface sealing plug	Used for sealing battery module parallel connection interface
14	Adjustable feet	Adjusts the distance between the battery base and the ground.
15	Waterproof and breathable plug	A sealing device that combines waterproof and breathable functions
16	Battery module parallel connection interface	Connects to next battery module or NA

## 4. Check and Storage

### 4.1 Check Before Receiving

Check the following items before receiving the product.

1. Check the outer packing box for damage, such as holes, cracks, deformation, and other signs of equipment damage. Do not unpack the contents from the box and contact the supplier as soon as possible if any damage is found.
2. Check the outer packing box for damage, such as holes, cracks, deformation, and other signs of equipment damage. Do not unpack the package and contact the supplier as soon as possible if any damage is found.
3. Check the deliverables for correct model, complete contents, and intact appearance. Contact the supplier as soon as possible if any damage is found

### 4.2 Deliverables

#### Master Battery module (LV14G-M)

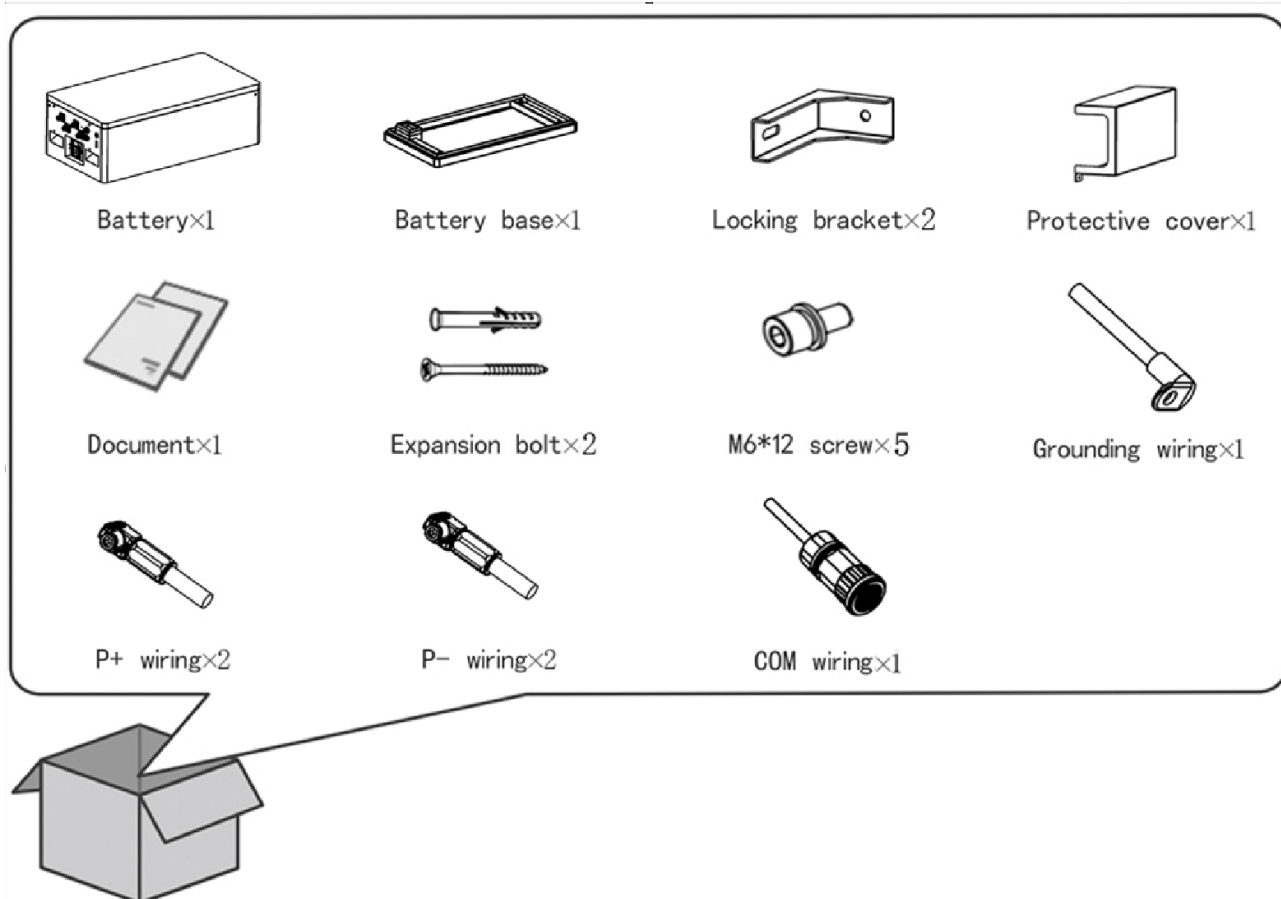

## Slave Battery module (LV14G-S)

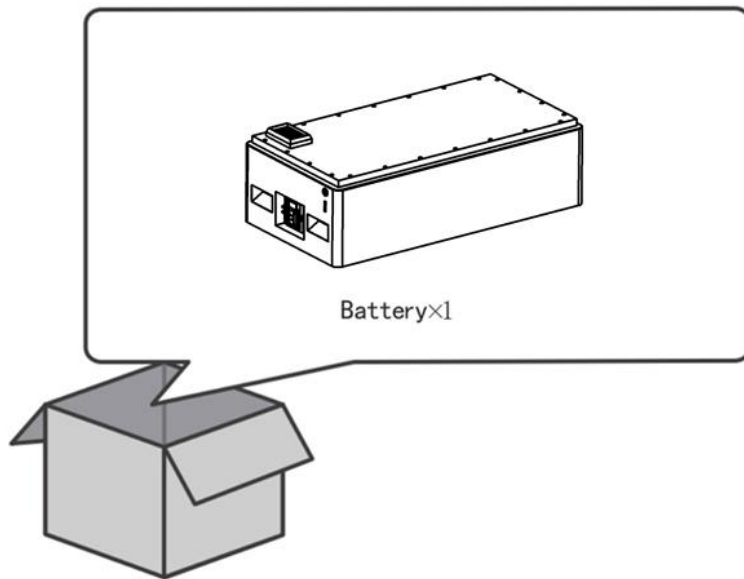

### 4.3 Storage

If the equipment is not to be installed or used immediately, please ensure that the storage environment meets the following requirements:

1. Do not unpack the outer package or throw the desiccant away.
2. Complete the equipment installation in three days after unpacking it. Pack and store the equipment using the original packing box if it is not installed.
3. Stack the equipment complying with the labels and requirements on the packing box.
4. The equipment must be stacked with caution to prevent them from falling.
5. Keep the equipment away from flammable, explosive, and corrosive matters.
6. Place the equipment in a cool place and avoid direct sunlight
7. Store the equipment in a clean place. Make sure the temperature and humidity are appropriate and no condensation.
8. Storage SOC: 25%~50% SOC. Circle the charge-discharge every 6 months.
9. Storage temperature (T):
  - When  $-20^{\circ}\text{C} \leq T < 0^{\circ}\text{C}$ , the storage period cannot exceed 1 month.
  - When  $0^{\circ}\text{C} \leq T \leq 35^{\circ}\text{C}$ , the storage period cannot exceed 1 year.
  - When  $35^{\circ}\text{C} < T \leq 45^{\circ}\text{C}$ , the storage period cannot exceed 1 month.
10. Recommended storage humidity: 0%~95%RH (no condensation). Do not install the battery system if there is any moisture or condensation

## 5. System Installation

### 5.1 Installation Requirements

#### NOTICE

Ensure that the installation requirements comply with local laws, regulations, and related standards.

#### Installation Environment Requirements

1. Do not install the equipment in a place near flammable, explosive, or corrosive materials.
2. Do not install the equipment in a place that is easy to touch, especially within children's reach.  
High temperature exists when the equipment is working. Do not touch the surface to avoid burning.
3. Avoid the water pipes and cables buried in the wall when drilling holes.
4. Install the equipment in a sheltered place to avoid direct sunlight, rain, and snow. Build a sunshade if it is needed.
5. The place to install the equipment shall be well-ventilated for heat dissipation and large enough for operations.
6. The equipment with a high ingress protection rating can be installed indoors or outdoors. The temperature and humidity at the installation site should be within the appropriate range.
7. Install the equipment at a height that is convenient for operation and maintenance, electrical connections, and checking indicators and labels.
8. The altitude to install the equipment shall be lower than the maximum working altitude 3000m.
9. Install the equipment away from electromagnetic interference. Install the product away from electromagnetic interference. If there is any radio or wireless communication equipment below 30MHz near the equipment, make sure that the inverter is at least 30m far away from the wireless Equipment.



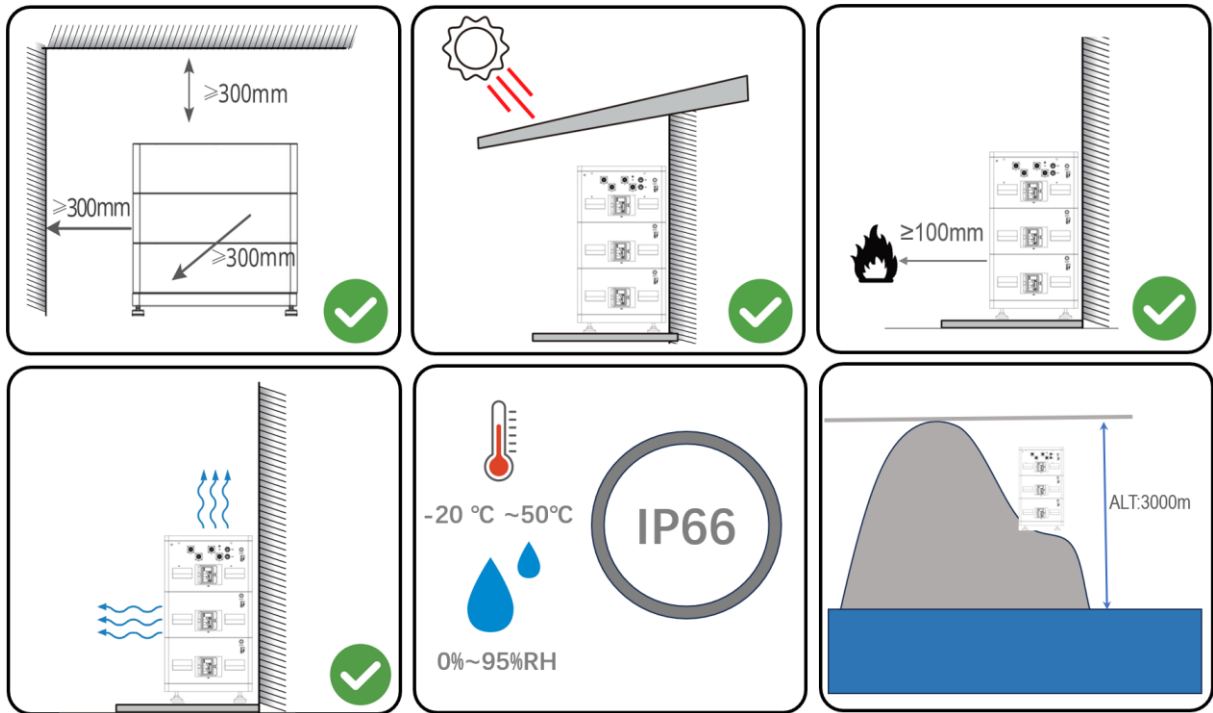

### Mounting Support Requirements

- The mounting support shall be nonflammable and fireproof.
- Install the equipment on a surface that is solid enough to bear the product weight.
- Put the battery system near the wall and install the locking brackets to prevent the battery from falling down

### Installation Angle Requirements

- Install the equipment vertically, no tilt or upside down.

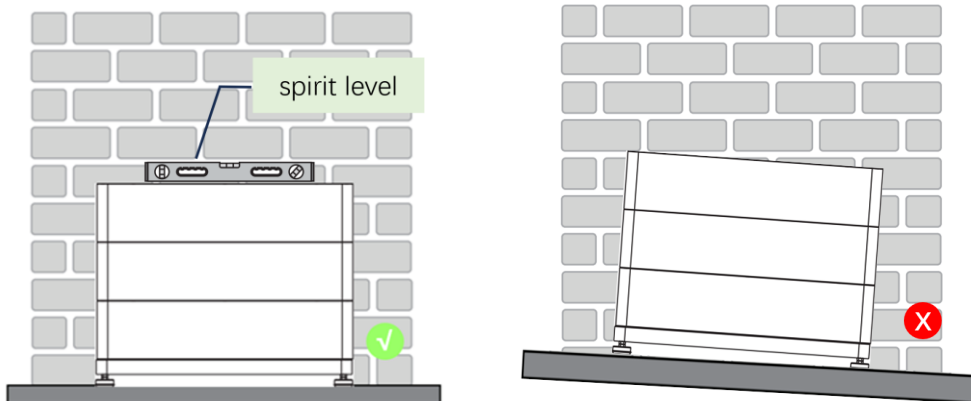

## 5.2 Installing the Battery System

### 5.2.1 Moving the Equipment

- Operations such as transportation, shipment, installation and so on shall in compliance with the laws and regulations of the country or region where the inverter is located.
- Move the equipment to the site before installation. Follow the instructions below to avoid personal injury or equipment damage.
  1. Consider the weight of the equipment before moving it. Assign enough personnel to move the equipment to avoid personal injury.
  2. Wear safety gloves to avoid personal injury.
  3. Keep balance to avoid falling down when moving the equipment.

## 5.2.2 Installing the Battery System



- Ensure that the master battery module is installed above the slave battery modules. Do not install any slave battery modules above the master battery module.
- Ensure that the battery system is installed vertically and securely. Align the installation holes of the battery base, battery modules. Put the locking bracket cling to the wall and the battery system.
- Cover the battery system with a cardboard to prevent foreign matters when drilling holes, which may damage the system

**Step 1:** The battery base pointing mark points outward

**Step 2:** The battery base is approximately 30~45 mm away from the wall, and adjust the adjustable rotating foot of battery base to keep the battery base in a horizontal position

**Step 3:** Carry the battery box to the installation site, (Due to the heavy weight of the battery, two people are required to carry it together). Install the first battery vertically downward, keeping level. Before installation, it is necessary to confirm that the battery module interfaces are on the same side

**Step 4:** Install the battery modules on the actual needs. The master battery module must be placed on the top layer

**Step 5:** Check whether the battery system is vertical and secure. Adjust the battery system by the adjust feet if the system is tilted or swayed.

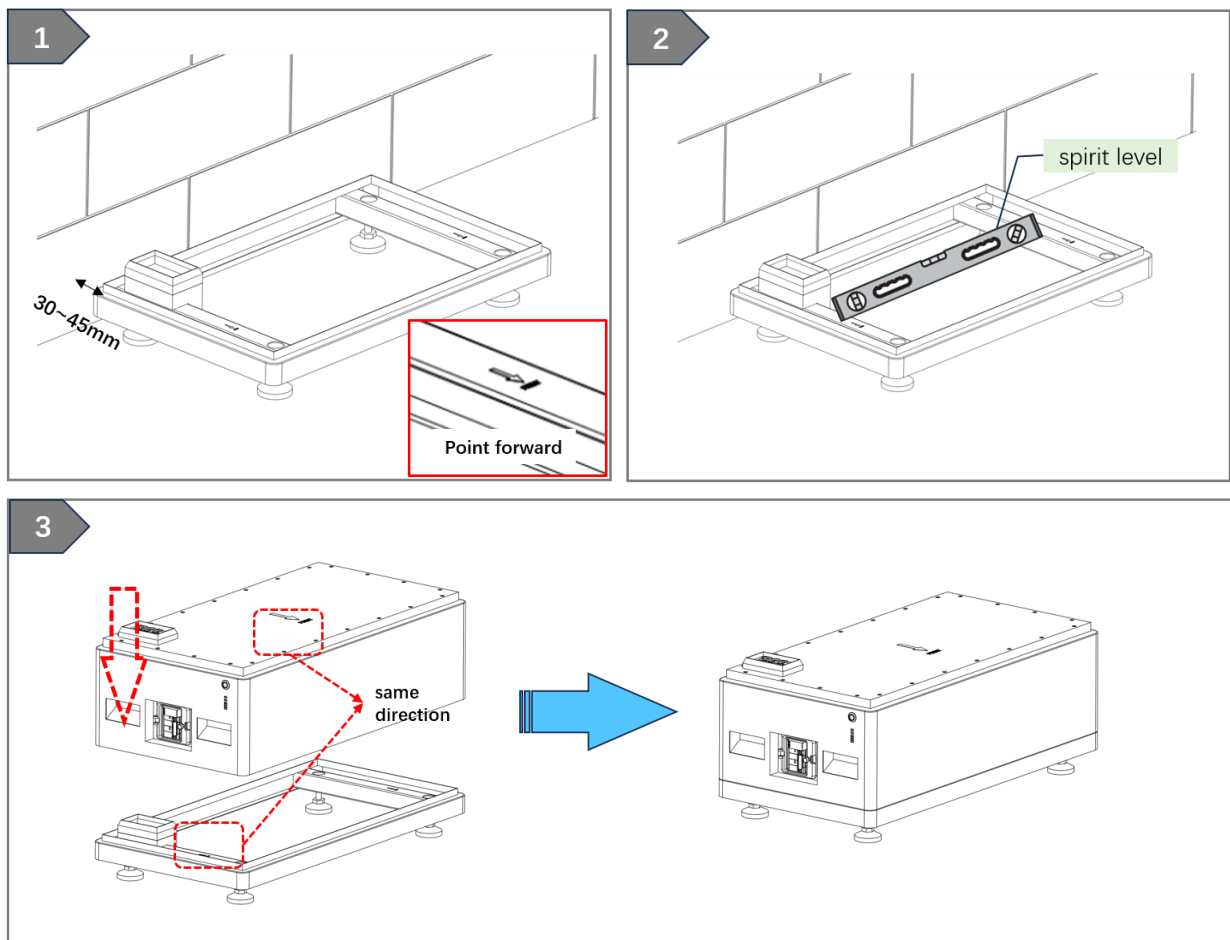

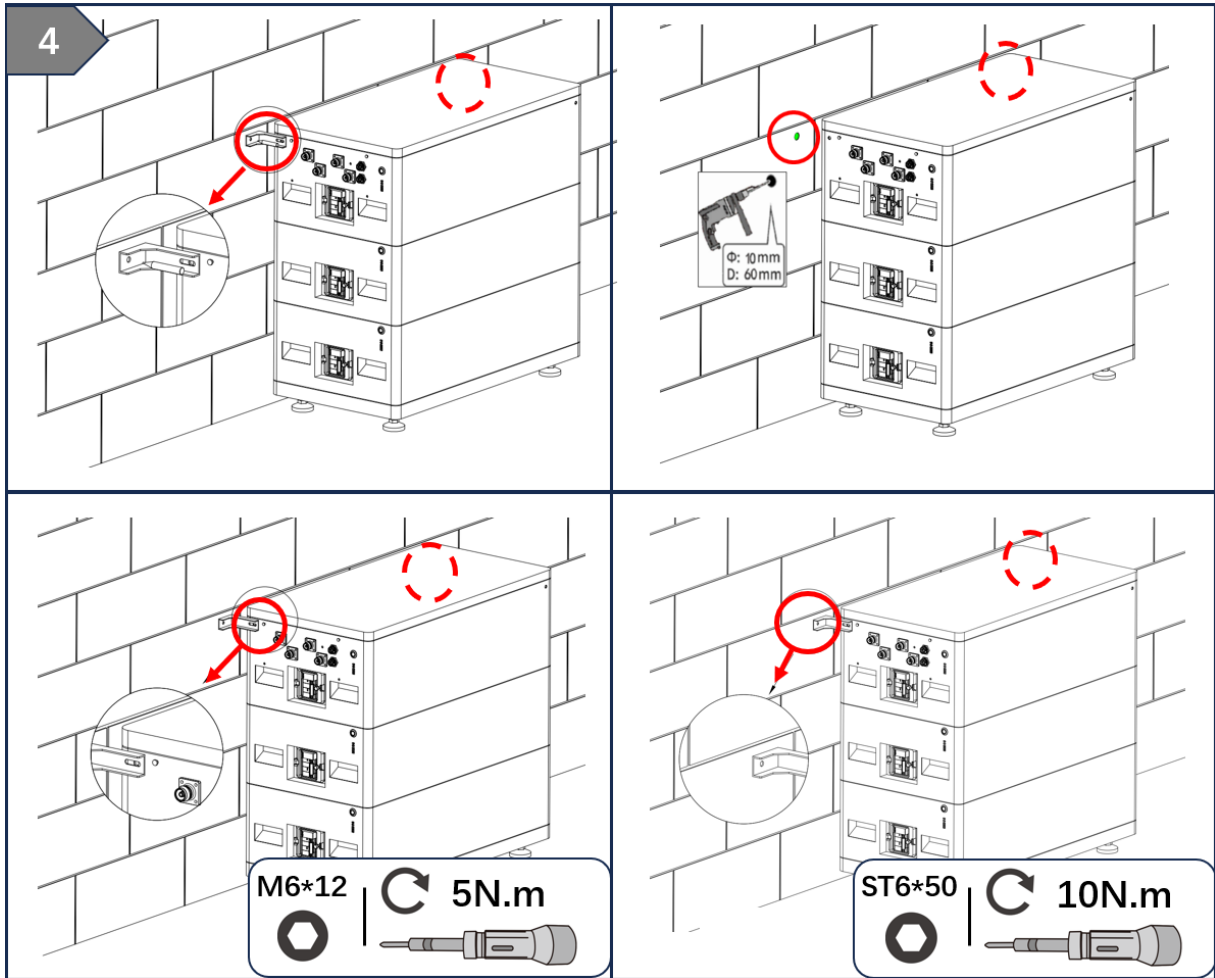

 CAUTION

Cover the battery system with a cardboard to prevent foreign matters when drilling holes, which may damage the system.

## 6. Electrical Connection

### 6.1 Safety Precaution

#### DANGER

- Ensure that the equipment has been powered off to avoid the risk of electric shock before operating the device in the system. Strictly follow all safety precautions outlined in this manual and safety labels on the equipment during the operation.
- All operations, cables and parts specification during the electrical connection shall be in compliance with local laws and regulations.
- Tie the cables of the same type together, and place cables of different types apart. Do not place the cables entangled or crossed.
- Make sure that the cable conductor is in full contact with the terminal and the cable insulation part is not crimped with the terminal when crimping the terminal. Otherwise, the inverter may not be able to work properly, or the connection may be unreliable during working, which may cause terminal block damage, etc.

#### NOTICE

- Wear personal protective equipment like safety shoes, safety gloves, and insulating gloves during electrical connections.
- All electrical connections should be performed by qualified professionals.
- Cable colors in this document are for reference only. The cable specifications shall meet local laws and regulations

### 6.2 Electrical Connection

#### Single Battery System

#### NOTICE

- Please ensure that the CAN communication port is connected to the inverter, COM communication port is debug port, For debugging only.

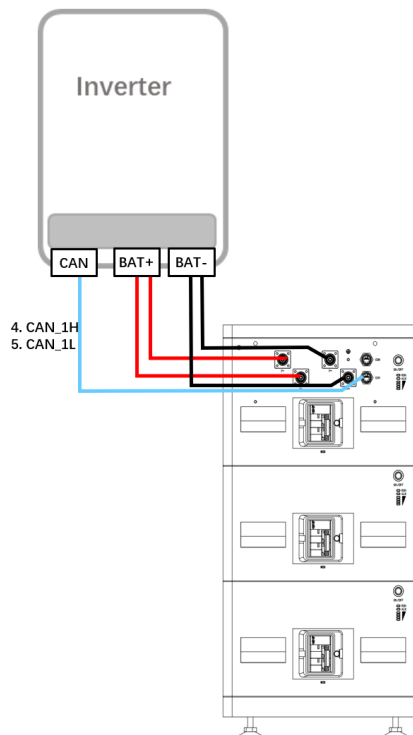

### 6.3 Connecting the PE cable

#### NOTICE

- Connect the PE cable first before installing the equipment. Disconnect the PE cable before dismantling the equipment.
- Make sure that the drawing force of the cable after crimping is greater than 400N
- The PE cable should be prepared by the customer. Recommended specifications:
  - Type: single-core or multi-core outdoor copper cable
  - Cross-sectional area: 4-6mm<sup>2</sup>

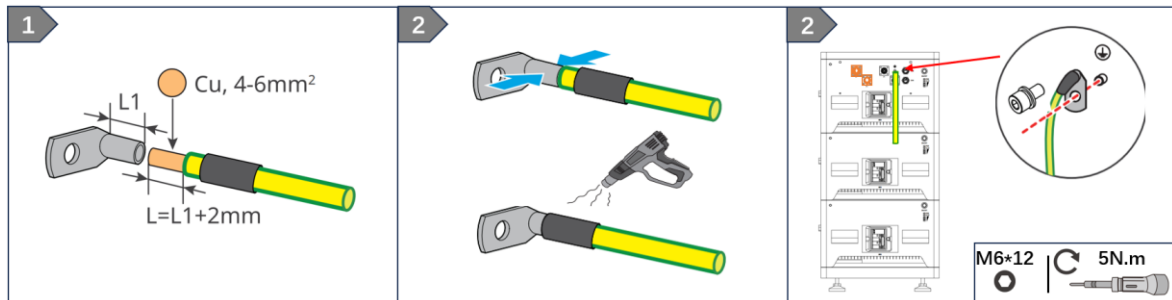

### 6.4 Connecting the Power Cable

#### WARNING

- The DC cable should be prepared by the customer. Recommended specifications:
  1. Type: multi-core copper Outdoor cable
  2. Conductor cross-sectional area S:  $S=70\text{mm}^2$
- When the cross-sectional area range of the conductor is 70mm<sup>2</sup> DC connector (included in the deliverables) should be used. The drawing force of the cable after crimping should be greater than 500N. DC cables in this range can only be used to connect a single battery system. Do not cluster battery systems together as this may result in damage to the system.
- It is recommended to use a YQK-70 hydraulic plier to crimp the DC terminal of the battery. When the cross-sectional area of the conductor is 70mm<sup>2</sup>, the crimping dies with an "70" should be used.  
If the recommended hydraulic plier cannot be purchased, please choose the crimping tool according to the terminal size to ensure that the crimped terminals meet the usage requirements.
- Do not remove the cover of the DC cable port if the DC cable is not to be connected. Otherwise, the protection degree may be influenced.

#### Crimping size

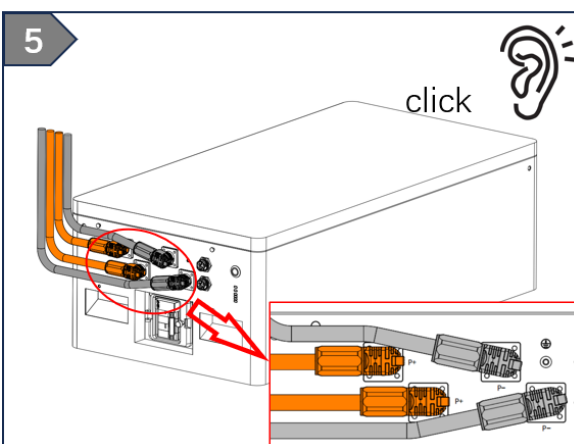
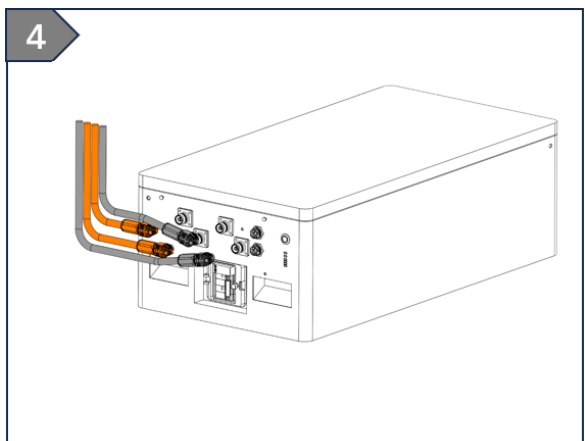
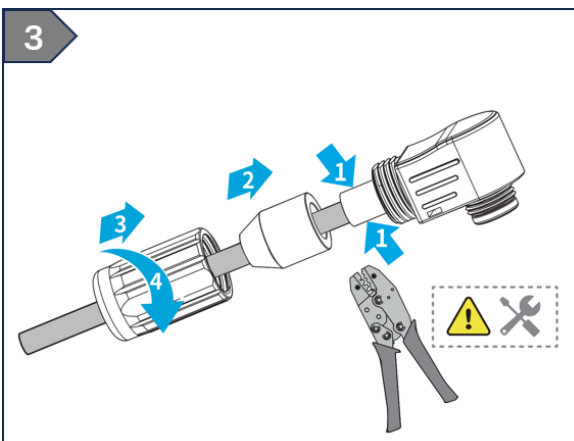
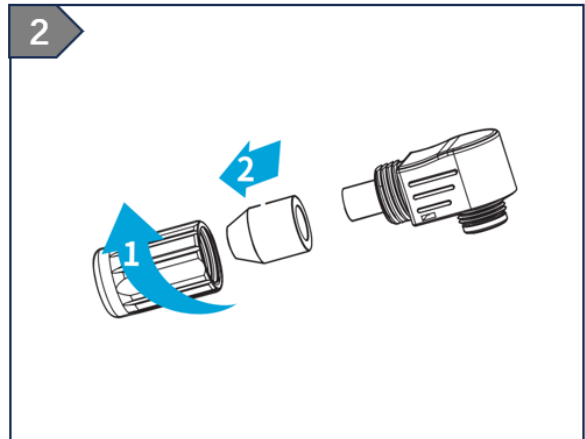
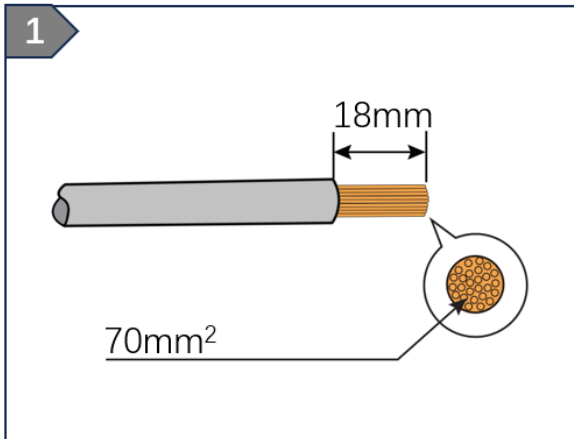
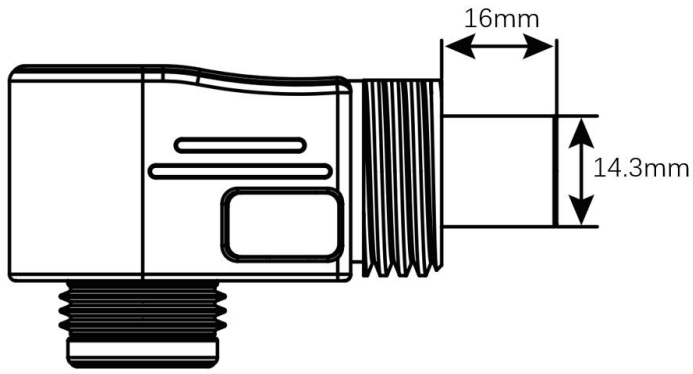

Model	Recommended cable

SR-LV14G-L1	70mm <sup>2</sup> *2
SR-LV14G-L2	
SR-LV14G-L3	70mm <sup>2</sup> *4 Or 90 mm <sup>2</sup> *2
SR-LV14G-L4	

1. Crimping the DC cable connector as required.
2. Connect the power cable to the interface.
3. For the battery power cable connection method on the inverter side, please refer to the inverter user manual

## 6.5 Connecting the Communication Cable

### Port Definition

Before connecting CAN cable with the battery, please check whether the communication pin sequence of the inverter and the battery match; If it does not match, you need to cut off the RJ45 connector at one end of the CAN cable and adjust the pin sequence according to the pin definitions of both inverter and battery.

Pin definition of the battery CAN Port is following EIA/TIA 568B.

CAN-H on Pin 4: Blue

CAN-L on Pin 5: Blue/White

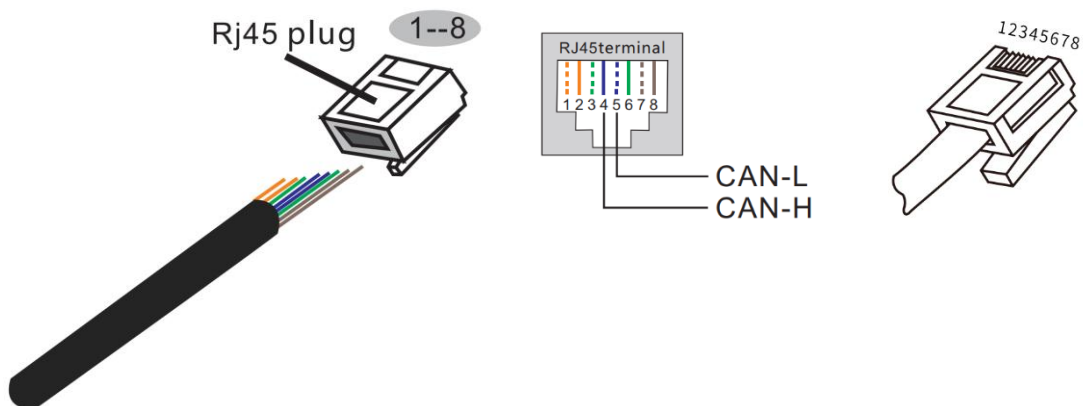

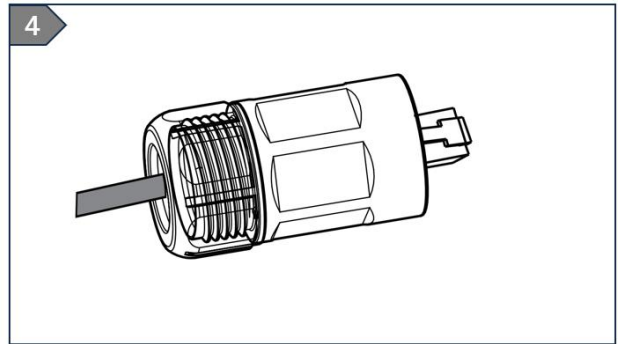
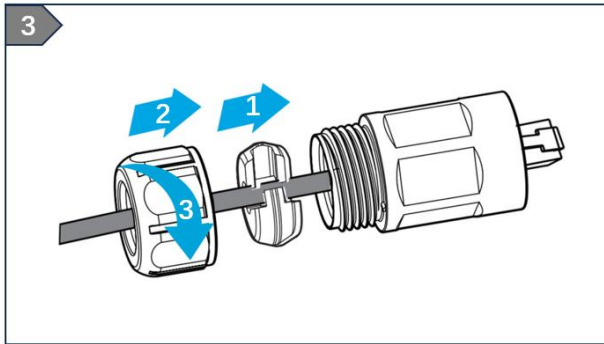
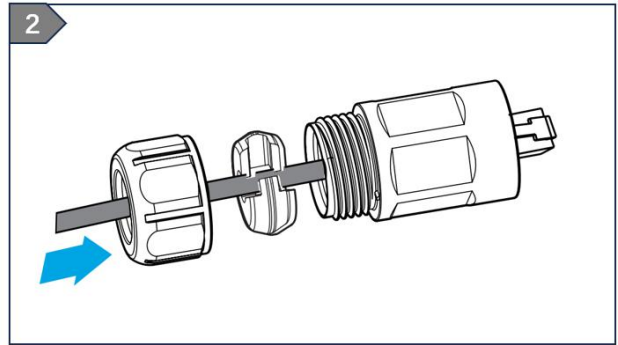
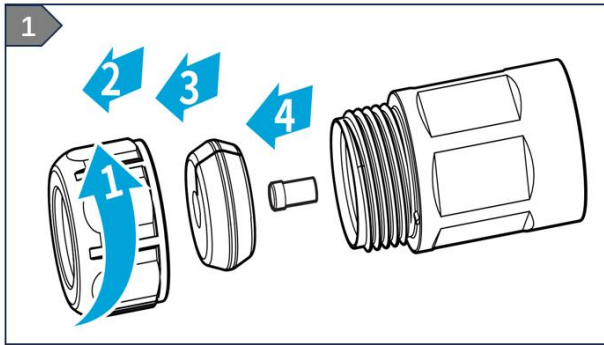

### Connecting the Communication Cable

Connect the communication cable to the battery system, Tighten the waterproof module

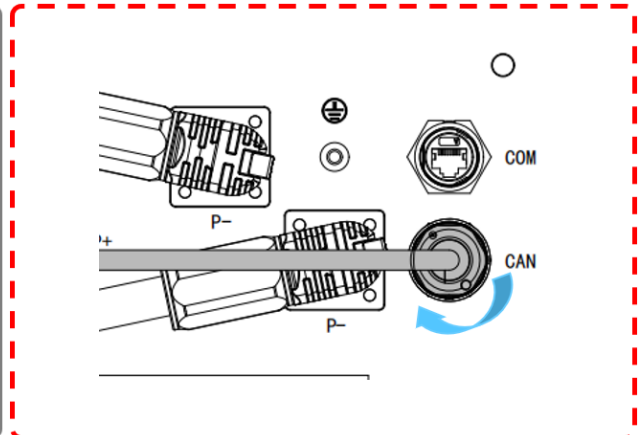
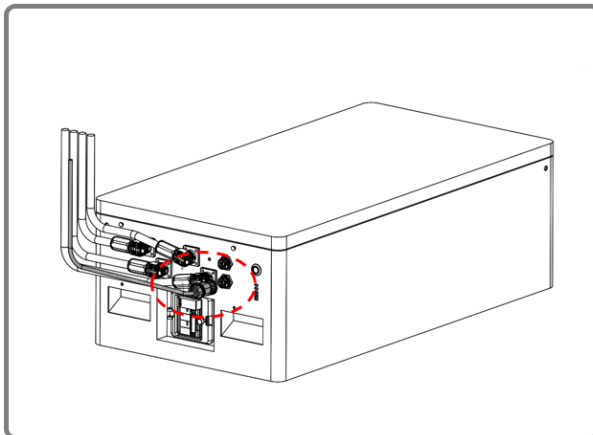

## 6.6 Installing the Protective Cover

The protective cover plate can only be installed after completing the wiring.

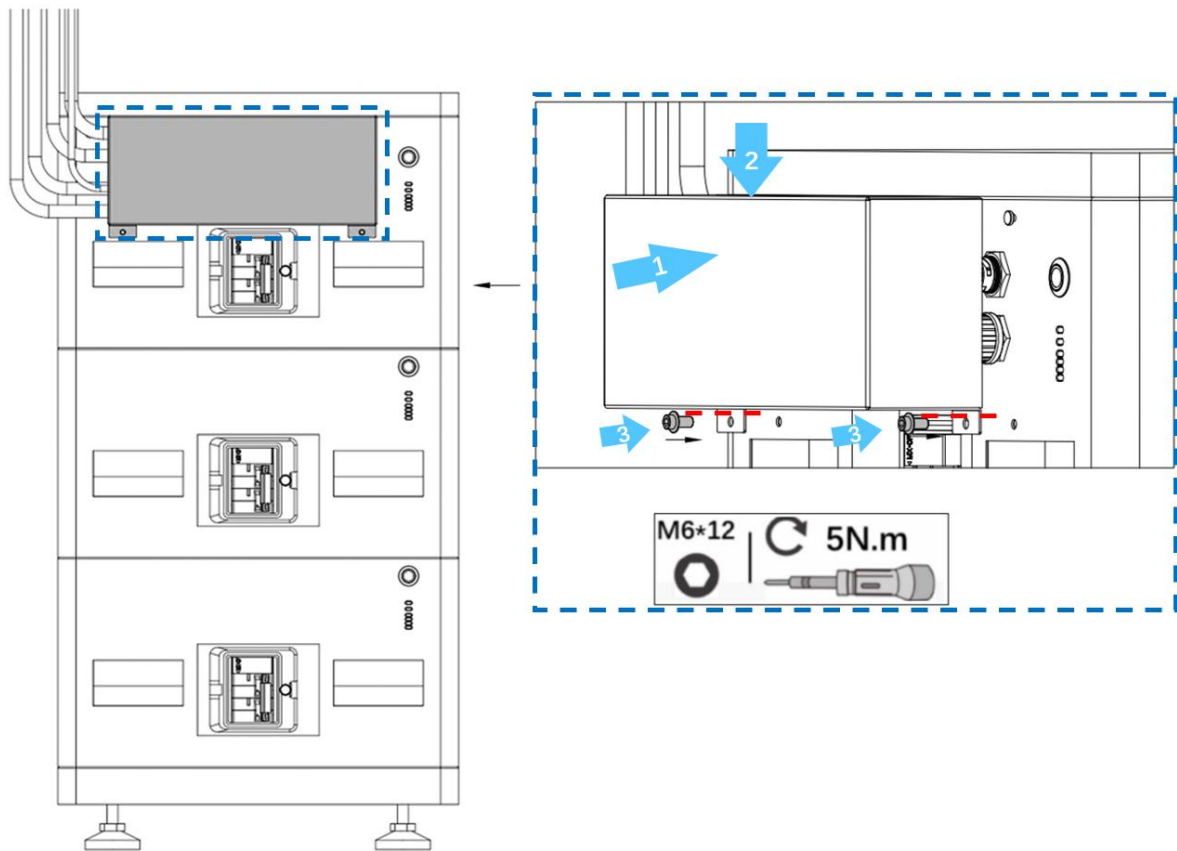

## 7. System Operation

### 7.1 Check Before Power ON

No	Check Item
1	The system is firmly installed in a clean place where is well-ventilated and easy to operate.
2	The PE cable, power cable, communication cable, and termination resistor are connected correctly and securely.
3	Cable ties are intact, routed properly and evenly.
4	Unused ports and terminals are sealed.

### 7.2 Power on

#### NOTICE

- The equipment in the dashed boxes are optional.
- Install the circuit breaker between the inverter and the battery with local laws and regulations.
- To ensure effective protection, the cover of the battery system switch should remain closed. The cover can be closed automatically after being opened. Fasten the cover with screws if the switch is not to be used for a long-term period.

**Step 1:** (Optional) Turn on the breaker between the inverter and the battery system.

**Step 2:** Turn on the breaker from bottom battery module to top battery module.

**Step 3:** Press the power button from bottom battery module to top battery module.

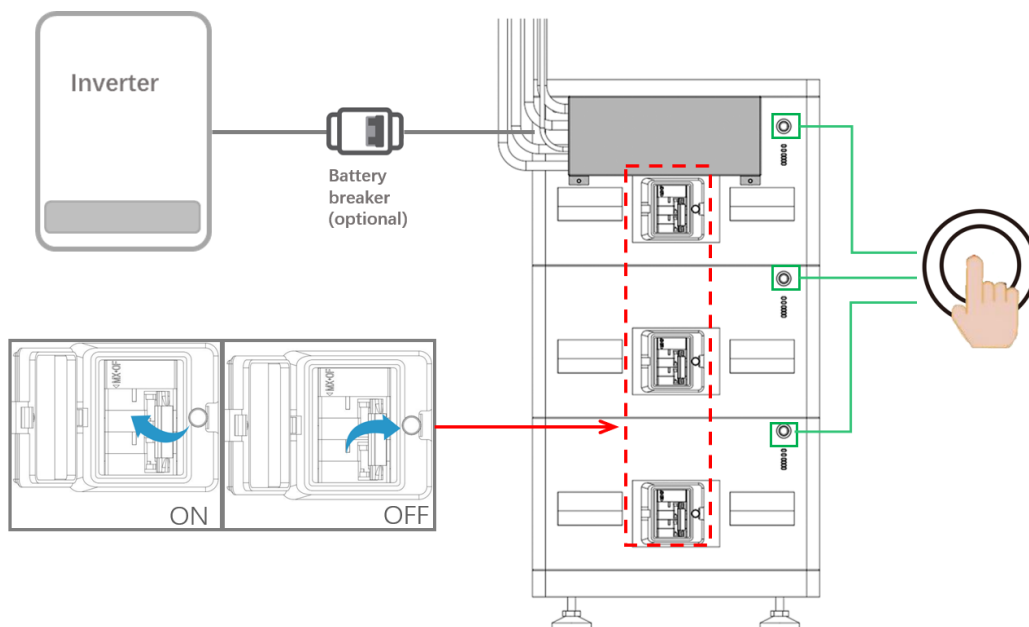

**Step 4:** Turn on the inverter in the system following the instructions in the user manual of the Inverter.

**Step 5:** Through the inverter monitoring to view battery operation data.



## 7.3 Indicator Status

When a system failure occurs, the LED indicator on the side panel will signal an alarm. The approximate alarm categories can be identified in the corresponding tables.

System status	Run status	RUN	ALM	SOC				Remark
								
Shut down	Standby	No light	No light	No light	No light	No light	No light	All LED no light
Standby	Normal	Blink 1 time/s	No light	No light	No light	No light	No light	Standby
Charge	normal	Always light	No light	According to the battery energy indicator				
	Overcurrent alarm	Always light	Blink 2 time/s	According to the battery energy indicator				
	Overvoltage protection	Blink 1 time/s	No light	No light	No light	No light	No light	
	Temperature or overcurrent protection	Blink 1 time/s	Blink 2 time/s	No light	No light	No light	No light	
Discharge	Normal	Blink 3 time/s	No light	According to the battery energy indicator				
	Alarm	Blink 3 time/s	Blink 3 time/s	According to the battery energy indicator				
	Temperature or overcurrent or short protection	No light	Always light	No light	No light	No light	No light	Stop discharge
	Low-voltage protection	No light	No light	No light	No light	No light	No light	Stop discharge

## 8. Maintenance

### 8.1 Power OFF the Battery System

#### DANGER

- Power off the battery system before operations and maintenance. Otherwise, the equipment may be damaged or electric shocks may occur.
- Strictly follow the power off requirements to avoid damaging the system.

#### NOTICE

- The equipment in the dashed boxes are optional.
- Install the circuit breaker between the inverter and the battery with local laws and regulations.
- To ensure effective protection, the cover of the battery system switch should remain closed. The cover can be closed automatically after being opened. Fasten the cover with screws if the switch is not to be used for a long-term period.

**Step1:** Turn off the inverter in the system following the instructions in the user manual of the Inverter.

**Step 2:** Press the power button from top battery module to bottom battery module, then the button return (to the released position)

**Step 3:** Turn off the breaker from top battery module to bottom battery module.

**Step 4:**(Optional) Turn off the breaker between the inverter and the battery system

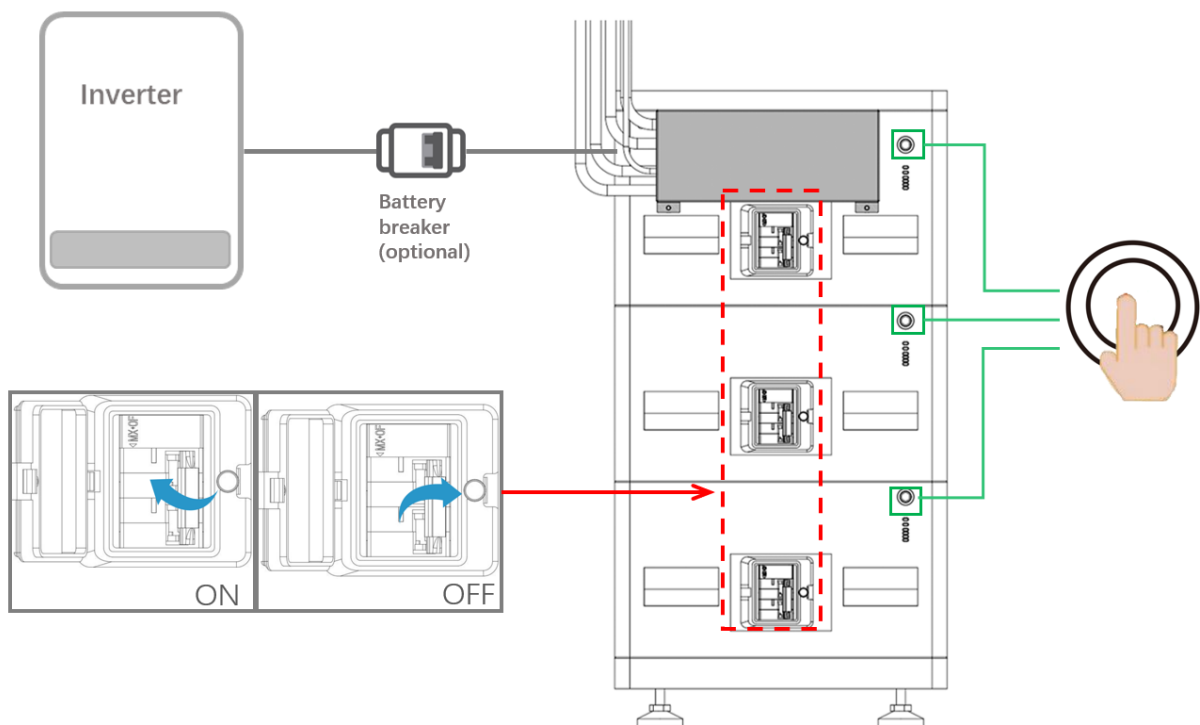

## 8.2 Routine Maintenance

 **WARNING**

- Contact the after-sales service for help if you find any problems that may influence the battery or the hybrid inverter. Disassemble without permission is strictly forbidden.
- Contact after-sale service for help if the copper conductor is exposed. Do not touch or disassemble privately because the high voltage danger exists.
- In case of other emergencies, contact the after-sales service as soon as possible. Operate following the instructions or wait for the after-sales service personnel

Maintaining Item	Maintaining Period
Check whether the locking bracket is secured, tighten it if not	Once every 6 months
Check whether there is any dust around the battery module. Clean the dust if there is any to avoid affecting heat dissipation.	Once every 6 months
Check whether there is any liquid or pest near the battery to avoid intrusion in a long term.	Once every 6 months
Check whether the cables are exposed. Replace the exposed cable or contact the after-sales service for help.	Once every 6 months
Check whether the outer enclosure is broken. Repair the painting or contact the after-sales service if there is any broken	Once every 6 months

## 8.3 Common Problem Handling

Problem	Cause	Solutions
Battery system tilt	The ground is uneven or deformed	1. Adjust the height of the anchor nut. 2. Replace to hard ground.
The gap is too large of each battery module to stack	battery module in the battery system are not corresponding	Adjust the module position to ensure that the battery modules are stacked without misalignment.
The indicator light goes out and the battery switch trips during operation	Cable short circuit or internal failure of battery system.	1. Check for short circuits in external cables. 2. Power off and wait for 2 hours, then power on.



## Suzhou Sumray Digital Energy Technology Co.,Ltd

 Room 3002, Building 3, No. 111, Cai Zi Road, Jiangling Street, Wujiang District, Suzhou,China

 <https://www.sumrayinverter.com/>

 [services@sumrayinverter.com](mailto:services@sumrayinverter.com)